

RTC-8070

Rough Terrain Crane
70-ton (63.50 mt)

GUAY



- 70-ton at 9 ft (2.74 m) radius
- 202 ft (61.57 m) maximum tip height
- 93,514 lbs (42,417 kg) gross vehicle weight (fully loaded)
- 41 ft to 127 ft (12.50 m to 38.71 m) full power, four-section boom with quick reeve boom head
- Optional 67 ft (20.42 m) two-piece (bi-fold) lattice fly, stowable, offsettable to 2°, 20° and 40°
- Microguard 434 rated capacity limiter
- Off-highway 225 hp (168 kW) Caterpillar engine
- Spicer 6 speed power shift transmission
- Pilot-operated hydraulic controls
- 19.5 mph (31.4 km/hr) travel speed
- 12 ft 7 in (3.84 m) wheel base



Link-Belt
CRANES

www.linkbelt.com



RTC-8070

Rough Terrain Crane

Superior performance, control and reliability

The RTC-8070 is jam-packed with power, control & reliability !

- Caterpillar 3126B electronic engine with 225 hp (168 kW) provides 646 lb-ft (876 Nm) of torque
- Remote-mounted, thermostatically controlled oil cooler provides maximum transmission cooling under the most extreme job site conditions
- Electronic throttle for improved throttle response
- Three automotive-style batteries linked in parallel and provide 700 cold cranking amps for cold weather starting
- Rugged, lightweight steel pontoons
- Hydraulic disc brakes for both service brakes and parking brake
- Metri-Pak wire harnesses have sealed relays and connectors throughout for outstanding long-term reliability. All wires have flame retardant polyethylene insulation, resulting in a higher heat resistant wiring system.

4-section full power boom with attachment flexibility

- Full power 41 ft to 127 ft (12.50 m to 38.71 m) four-section boom with two extend modes: **A-max and fully synchronized**
- Features the "Boss," Link-Belt's patented boom design of high strength angle cords and high formability sidewall embossments.
- Maximum tip height is 202 ft (61.57 m) with the attachment and main boom used in combination
- Optional 39 ft 6 in (12.04 m) one-piece lattice fly and optional 39 ft 6 in to 67 ft (12.04 m to 20.42 m) two-piece bi-fold lattice fly are offsettable to 2°, 20° and 40°.



A-max extends only the inner-mid section of the boom for substantially increased capacities for in-close, maximum capacity lifts.



Operator cab features

- Large front window for excellent visibility
- Tinted glass
- Sliding right side and rear windows and swing-up top window provide excellent ventilation
- Integral rated capacity limiter aids the operator in safe and efficient operation by continuously monitoring boom length, boom angle, head height, radius of load, machine configuration, allowed load and percent of allowed load.

Powerful hydraulics

- For greater productivity and control, the six-pump hydraulic circuit allows simultaneous function of boom hoist, winch and swing.
- Piston motor hydraulic hoist system delivers superior hoisting. Matched sizes of main and auxiliary winches provide equal maximum available line pulls of 16,506 lbs (7 487 kg) and maximum line speeds of 454 fpm (138 m/min) on 16" (.41 m) root diameter drums.

Job site maneuverability

- Steering modes are chosen and performed with the steering wheel and include independent front steer, four wheel steer, and "crab" steering.
- CALC — Outrigger beams have three lifting stages (retracted, intermediate and fully extended) providing lifting capacities in confined areas.

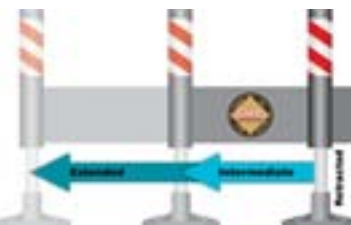

Engine hood design provides easy access for maintenance.



Fast & efficient hydraulic counterweight removal enhances roadability



Transmission oil is cooled by a thermostatically-controlled oil cooler to provide maximum cooling under the most extreme job conditions.

Invest in a legacy of outstanding customer support

- Distributor support personnel - Factory-trained technicians are specifically tested to establish proficiency in all aspects of crane diagnostics and repair.
- Factory product support team - Supporting your trained distributor personnel are experienced factory advisors with comprehensive records and technical libraries that stand ready to resolve any crane service issue.
- Parts Distribution Center - 72,000 sq. ft. Parts Distribution Center averages an over-90% parts availability rate.

- eParts - Link-Belt's online computer system links our distributors worldwide so customers can order genuine Link-Belt parts 24 hours a day, 7 days a week.
- Link-Belt Preferred - Link-Belt's customer web site provides instant access to a comprehensive library of all parts, service and operator manuals plus other technical and sales information.

Link-Belt
Preferred

© Link-Belt is a registered trademark. Copyright 2003. All rights reserved. We are constantly improving our products and therefore reserve the right to change designs and specifications.
Litho in U.S.A. 12/03 #4284



■ Axle Loads

Base machine with standard 41' to 127' (12.50 – 38.71 m) four-section boom, 2M main winch with 2-speed hoisting and power up/down, 670' (204 m) 3/4" (19 mm) wire rope. 4x4x4 carrier with Caterpillar 3126B 7.2L engine, 29.5 x 25 tires, counterweight and no fuel.	G.V.W. ¹		Upper facing front				Upper facing rear			
			Front axle		Rear axle		Front axle		Rear axle	
	lbs.	kg.	lbs.	kg.	lbs.	kg.	lbs.	kg.	lbs.	kg.
	93,514	42 417	43,540	19 749	49,974	22 668	42,540	19 296	50,974	23 121
Remove 29.5 x 25 tires and wheels	-6,732	-3 054	-3,366	-1 527	-3,366	-1 527	-3,366	-1 527	-3,366	-1 527
29.5R25 XHA Tires	964	438	482	219	482	219	482	219	482	219
Remove outrigger beams	-5,235	-2 374	-2,461	-1 116	-2,774	-1 258	-2,461	-1 116	-2,774	-1 258
Jack cylinder beams	154	70	72	33	82	27	72	33	82	37
Tow winch	686	311	1,002	454	-316	-143	1,002	454	-316	-143
100 gallons (378.5 L) fuel	685	310	364	165	321	145	364	165	321	145
2M auxiliary winch with 670' (204 m) of 3/4" (19 mm) rope	823	373	-219	-99	1,043	473	977	443	-154	-70
Remove front carrier counterweights	-1,000	-454	-1,306	-592	306	139	-1,306	-592	306	139
Hydraulic counterweight removal	353	160	163	74	190	86	518	235	-165	-75
Remove counterweight	-15,000	-6 804	8,223	3 734	-23,233	-10 538	-22,041	-9 998	7,041	3 194
Air conditioning	287	130	55	25	232	105	209	95	78	35
39.5' (12.04 m) offsettable lattice fly stowed	1,602	727	2,780	1 261	-1,178	-534	-1,305	-592	2,907	1 319
39.5' – 67' (12.04 – 20.42 m) offsettable lattice fly stowed	2,380	1 080	3,649	1 655	-1,269	-576	-1,458	-661	3,838	1 741
Fly storage brackets with all fly options	160	73	268	122	-108	-49	-120	-54	280	127
Auxiliary lifting sheave assembly	110	50	361	164	-251	-114	-260	-118	370	168
8.5-ton (7.71 mt) hook ball @ front bumper	360	163	566	256	-206	-93	n/a	n/a	n/a	n/a
70-ton (63.50 mt) 5-sheave hook block @ front bumper	1,390	631	2,186	992	-796	-361	n/a	n/a	n/a	n/a
60-ton (54.43 mt) 4-sheave hook block @ front bumper	1,150	522	1,809	821	-659	-299	n/a	n/a	n/a	n/a

¹ – Adjust gross weight and axle loading according to component weight. Note: All weights are ± 3%.

Tire	Max. Axle Load @ 20 mph (32.7 km/hr)
29.5 x 25 (28-PR)	53,000 (24 041 kg)
29.5R25 XHA 1 Star	53,000 (24 041 kg)

Lifting Capacities

Telescopic Rough Terrain Crane

RTC-8070

70-ton (63.5 metric ton)

Boom and fly capacities for this machine are listed by the following sections:

Fully Extended Outriggers

- Working Range Diagram (15,000 lb. Counterweight)
- 41' to 69' 6" main boom capacities, **A-max** Mode
- 41' to 127' main boom capacities, Basic Mode "B"
- 39' 6" offset fly capacities, Basic Mode "B"
- 39' 6" to 67' Two-piece offsettable fly capacities, Basic Mode "B"

On Tires

- Working Range Diagram (15,000 lb. Counterweight)
- 41' to 69' 6" main boom capacities, **A-max** Mode
- 41' to 90' main boom capacities, Basic Mode "B"

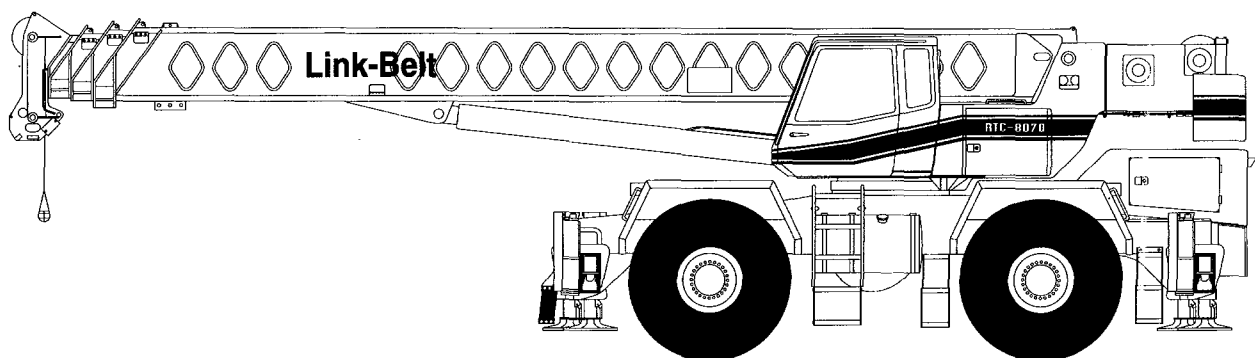

CAUTION: This material is supplied for reference only. Operator must refer to in-cab crane rating manual to determine allowable machine lifting capacities and operating procedures.

Table of Contents

Page	Contents
3-4	Operating Instructions
5	A -max Mode & Basic Mode "B" Boom Extension Diagram
5	Winch Performance
5	Wire Rope Strength
5	Working Areas
5	Hydraulic Circuit Pressure Settings
5	Capacity Deductions For Auxiliary Load Handling Equipment
5	Tire Inflation
5	Pontoon Loadings
5	Outrigger Spread

Fully Extended Outriggers

6	Working Range Diagram
7	Main Boom Lifting Capacities
8	Fly Lifting Capacities

On Tires

9	Working Range Diagram
10-11	Main Boom Lifting Capacities - 29.5 x 25 (28-PR) Tires

OPERATING INSTRUCTIONS

GENERAL:

1. Rated lifting capacities in pounds as shown on lift charts pertain to this crane as originally manufactured and normally equipped. Modifications to the crane or use of optional equipment other than that specified can result in a reduction of capacity.
2. Construction equipment can be dangerous if improperly operated or maintained. Operation and maintenance of this crane must be in compliance with the information in the Operator's, Parts, and Safety Manuals supplied with this crane. If these manuals are missing, order replacements through the distributor.
3. The operator and other personnel associated with this crane shall read and fully understand the latest applicable American National Standards ASME B30.5 safety standards for cranes.
4. The rated lifting capacities are based on crane standing level on firm supporting surface.

SET UP:

1. The crane shall be leveled on a firm supporting surface. Depending on the nature of the supporting surface, it may be necessary to have structural supports under the outrigger pontoons or tires to spread the load to a larger bearing surface.
2. When making lifts on outriggers, all tires must be free of supporting surface. All outrigger beams must be extended to the same length; fully retracted, intermediate extended, or fully extended.
3. When making lifts on tires, they must be inflated to the recommended pressure. (See Operation note 20 and Tire Inflation.)
4. When operating on tires over the side, do not exceed 66 degree maximum boom angle. Loss of backward stability will occur causing a backward tipping condition.
5. When operating with 0 pound counterweight, do not swing over side on tires unless boom is fully retracted and boom angle is above 45° .
6. For required parts of line, see Wire Rope Capacity and Winch Performance.
7. Before setting up on intermediate outriggers, retracted outriggers, or tires, refer to Working

Range Diagrams and rated lifting capacities to determine allowable crane configurations.

OPERATION:

1. Rated lifting capacities at rated radii shall not be exceeded. Do not tip the crane to determine allowable loads. For concrete bucket operation, weight of bucket and load shall not exceed 80% of rated lifting capacities. For clamshell bucket operation, weight of the bucket and bucket contents is restricted to a maximum weight of 7000 pounds or 80% of rated lifting capacity, whichever is less. For magnet operation, weight of the magnet and load is restricted to a maximum weight of 7000 pounds or 80% of rated lifting capacity, whichever is less. For clamshell and magnet operation, maximum boom length is restricted to 60 ft. and the boom angle is restricted to a minimum of 35° . Lifts with either fly erected are prohibited for both clam and magnet operation.
2. Rated lifting capacities shown on fully extended outriggers do not exceed 85% of the tipping loads. Rated lifting capacities shown on intermediate extended or fully retracted outriggers are determined by the formula, rated load = (tipping load - 0.1 X load factor)/1.25. Rated lifting capacities shown on tires do not exceed 75% of the tipping loads. Tipping loads are determined by SAE crane stability test code J-765.
3. Rated lifting capacities in the shaded areas are based on structural strength or hydraulic limitations and have been tested to meet minimum requirements of SAE J-1063 cantilevered boom crane structures - method of test. The rated lifting capacities in non-shaded areas are based on stability ratings. Some capacities are limited by a maximum obtainable 78° boom angle.
4. Rated lifting capacities include the weight of the hook ball/block, slings, bucket, magnet and auxiliary lifting devices. Their weights must be subtracted from the listed rated capacity to obtain the net load which can be lifted. Rated lifting capacities include the deduct for either fly stowed on the base of the boom. For deducts of either fly

Operating Instructions (*continued*)

- erected, but not used, see Capacity Deductions For Auxiliary Load Handling Equipment.
5. Rated lifting capacities are based on freely suspended loads. No attempt shall be made to move a load horizontally on the ground in any direction.
 6. Rated lifting capacities are for lift crane service only.
 7. Do not operate at any radii or boom lengths (minimum or maximum) where capacities are not listed. At these positions, the crane can tip or cause boom failure.
 8. The maximum loads which can be telescoped are not definable because of variation in loadings and crane maintenance, but it is permissible to attempt retraction and extension within the limits of the applicable load rating chart.
 9. For main boom capacities when either boom length or radius or both are between values listed, proceed as follows:
 - a. For boom lengths not listed, use rating for next longer boom length or next shorter boom length, whichever is smaller.
 - b. For load radii not listed, use rating for next larger radius.
 10. The user shall operate at reduced ratings to allow for adverse job conditions, such as: soft or uneven ground, out of level conditions, wind, side loads, pendulum action, jerking or sudden stopping of loads, hazardous conditions, experience of personnel, traveling with loads, electrical wires, etc. Side load on boom or fly is dangerous and shall be avoided.
 11. Rated lifting capacities do not account for wind on suspended load or boom. Rated capacities and boom length shall be appropriately reduced as wind velocity approaches 20 mph.
 12. When making lifts with auxiliary head machinery, the effective length of the boom increases by 2 feet.
 13. Power sections of boom must be extended in accordance with boom mode "A" or "B". In boom mode "B" all power sections must be extended or retracted equally.
 14. The least stable rated working area depends on the configuration of the crane setup.
 15. Rated lifting capacities are based on correct reeving. Deduction must be made for excessive reeving. Any reeving over minimum required (see Wire Rope Capacity) is considered excessive and must be accounted for when making lifts. Use Working Range Diagram to estimate the extra feet of rope then deduct 1 lb for each extra foot of wire rope before attempting to lift a load.
 16. The loaded boom angle combined with the boom length give only an approximation of the operating radius. The boom angle, before loading, should be greater to account for deflection. For main boom capacities, the loaded boom angle is for reference only. For fly capacities, the load radius is for reference only.
 17. For fly capacities with main boom length less than 127 ft. and greater than 100 ft., the rated capacities are determined by the boom angle using the 127 ft. boom and fly chart. For angles not shown use the next lower boom angle to determine the rated capacity.
 18. For fly capacities with main boom length less the 100 ft., the rated capacities are determined by the boom angle only using the 100 ft. boom and fly chart. For angles not shown, use the next lower boom angle to determine the rated capacity.
 19. The 41 ft. boom length structural capacities are based on boom fully retracted. If the boom is not fully retracted, do not exceed capacities shown for the 50 ft. boom length.
 20. Rated lifting capacities on tires depend on tire capacity, condition of tires, and tire air pressure. On tire capacities require lifting from main boom head only on a smooth and level surface. Pick and carry operations are restricted to a maximum speed of 1 mph. The boom must be centered over the front of the crane with two position travel swing lock engaged and the load must be restrained from swinging. Lifts with any fly erected on tires are prohibited. For correct tire pressure, see Tire Inflation.

DEFINITIONS:

1. Load Radius: Horizontal distance from a projection of the axis of rotation to the supporting surface, before loading, to the center of the vertical hoist line or tackle with load applied.
2. Loaded Boom Angle: \angle The angle between the boom base section and horizontal with freely suspended load at the rated radius.
3. Working Area: Area measured in a circular arc about the center line of rotation as shown on the Working Area Diagram.
4. Freely Suspended Load: Load hanging free with no direct external force applied except by the hoist line.
5. Side Load: Horizontal side force applied to the lifted load either on the ground or in the air.
6. No Load Stability Limit: The radius or boom angle beyond which it is not permitted to position the boom because the crane can overturn without any load on the hook.
7. Load Factor: Load applied at the boom tip which gives the same moment effect as the boom mass.

WORKING AREAS

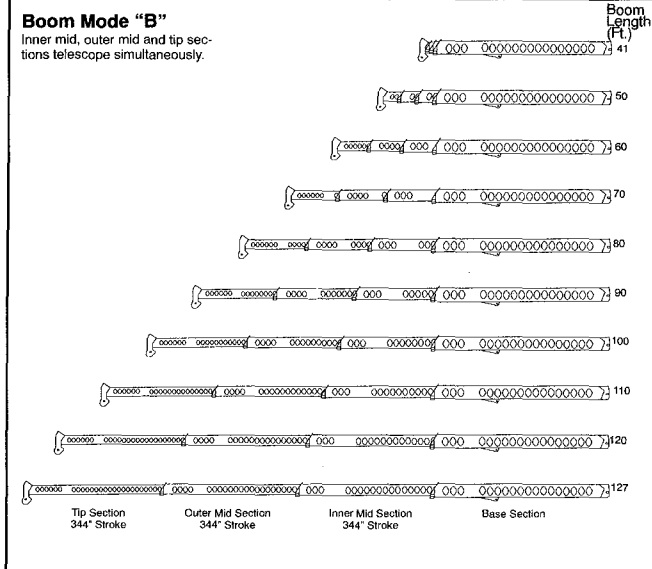
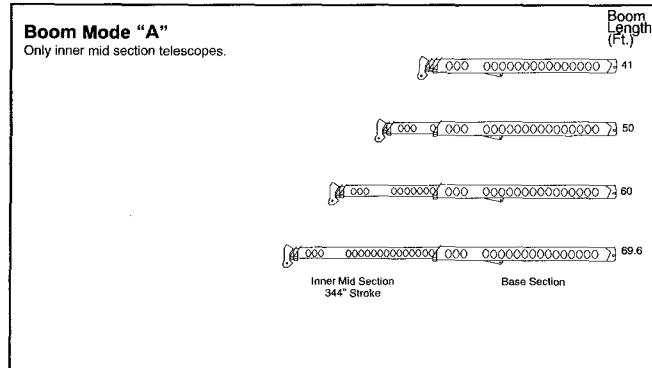
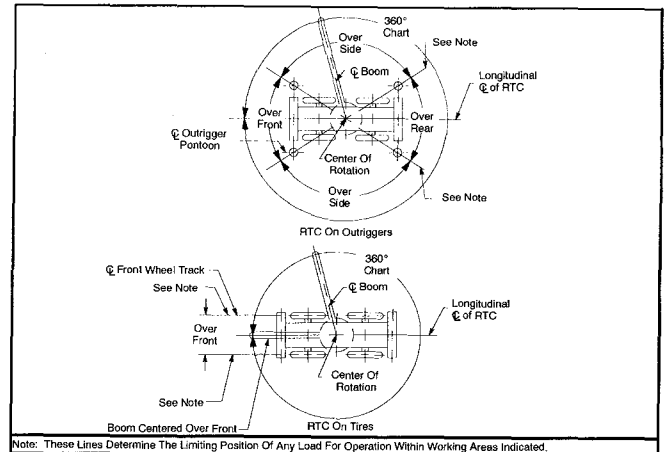

HYDRAULIC CIRCUIT PRESSURE SETTINGS

Function	Pressure (PSI)
Front And Rear Winch	3500
Outriggers	3000
Boom Hoist	3500
Telescope	3000
Swing	1500
Steering	2500
Pilot Control	500
Counterweight Removal	1700

CAPACITY DEDUCTIONS FOR AUXILIARY LOAD HANDLING EQUIPMENT

Load Handling Equipment	Weight (Lbs.)
Auxiliary Head Attached	100
40 Ton Quick Reeve 4 Sheave Hook Block (See Hook Block For Actual Weight)	720
60 Ton Quick Reeve 4 Sheave Hook Block (See Hook Block For Actual Weight)	1100
70 Ton Quick Reeve 5 Sheave Hook Block (See Hook Block For Actual Weight)	1400
8.5 Ton Hook Ball (See Hook Ball For Actual Weight)	360

Lifting From Main Boom With:	
39.5 Ft. Or 67 Ft. Fly Stowed On Base (See Operation Note 4)	0
39.5 Ft. Offset Fly Erected But Not Used	4100
67 Ft. Offset Fly Erected But Not Used	8200

Lifting From 39.5 Ft. Offset Fly With:	
27.5 Ft. Fly Tip Erected But Not Used	PROHIBITED
27.5 Ft. Fly Tip Stowed On 39.5 Ft. Offset Fly	PROHIBITED

Note: Capacity deductions are for Link-Belt supplied equipment only.

WINCH PERFORMANCE

Wire Rope Layer	Winch Line Pulls		Drum Rope Capacity (Ft.)	
	Two Speed Winch		Layer	Total
	Low Speed Available Lbs.*	High Speed Available Lbs.		
1	17,117	8,453	114	114
2	15,737	7,771	124	238
3	14,563	7,192	134	372
4	13,552	6,692	144	516
5	12,672	6,258	154	670
6	N/A	N/A	164	834

*Maximum lifting capacity: Type RB Rope=12,920 Type ZB Rope=15,600

WIRE ROPE CAPACITY

Parts of Line	Maximum Lifting Capacities Based On Wire Rope Strength		Notes
	3/4" Type RB	3/4" Type ZB	
1	12,920*	15,600	Capacities shown are in pounds and working loads must not exceed the ratings on the capacity charts in the Crane Rating Manual. Study Operator's Manual for wire rope inspection procedures. *Use of swivel end with 1 part of line is not recommended.
2	25,840	31,200	
3	38,760	46,800	
4	51,680	62,400	
5	64,600	78,000	
6	77,520	93,600	
7	90,440	109,200	
8	103,360	124,800	
9	116,280	140,400	
10	129,200	156,000	

LBCE	DESCRIPTION
TYPE RB	18 X 19 Rotation Resistant - Compact Strand - High Strength, Preformed, Right Regular Lay
TYPE ZB	36 X 7 Rotation Resistant - Extra Improved Plow Steel - Right Regular Lay

TIRE INFLATION

Tire Size	Operation	Tire Pressure (PSI)
29.5 x 25-28 PR	1 MPH Stationary	75
		75

PONTOON LOADINGS

Maximum Pontoon Load:	Maximum Pontoon Ground Bearing Pressure:
94,000 Lbs.	208 PSI

OUTRIGGER SPREAD

Position	Distance
Fully Retracted	(120.75') 10'-3/4"
Intermediate Extended	(196.75') 16'-4 3/4"
Fully Extended	(276") 23'-0"

WORKING RANGE DIAGRAM

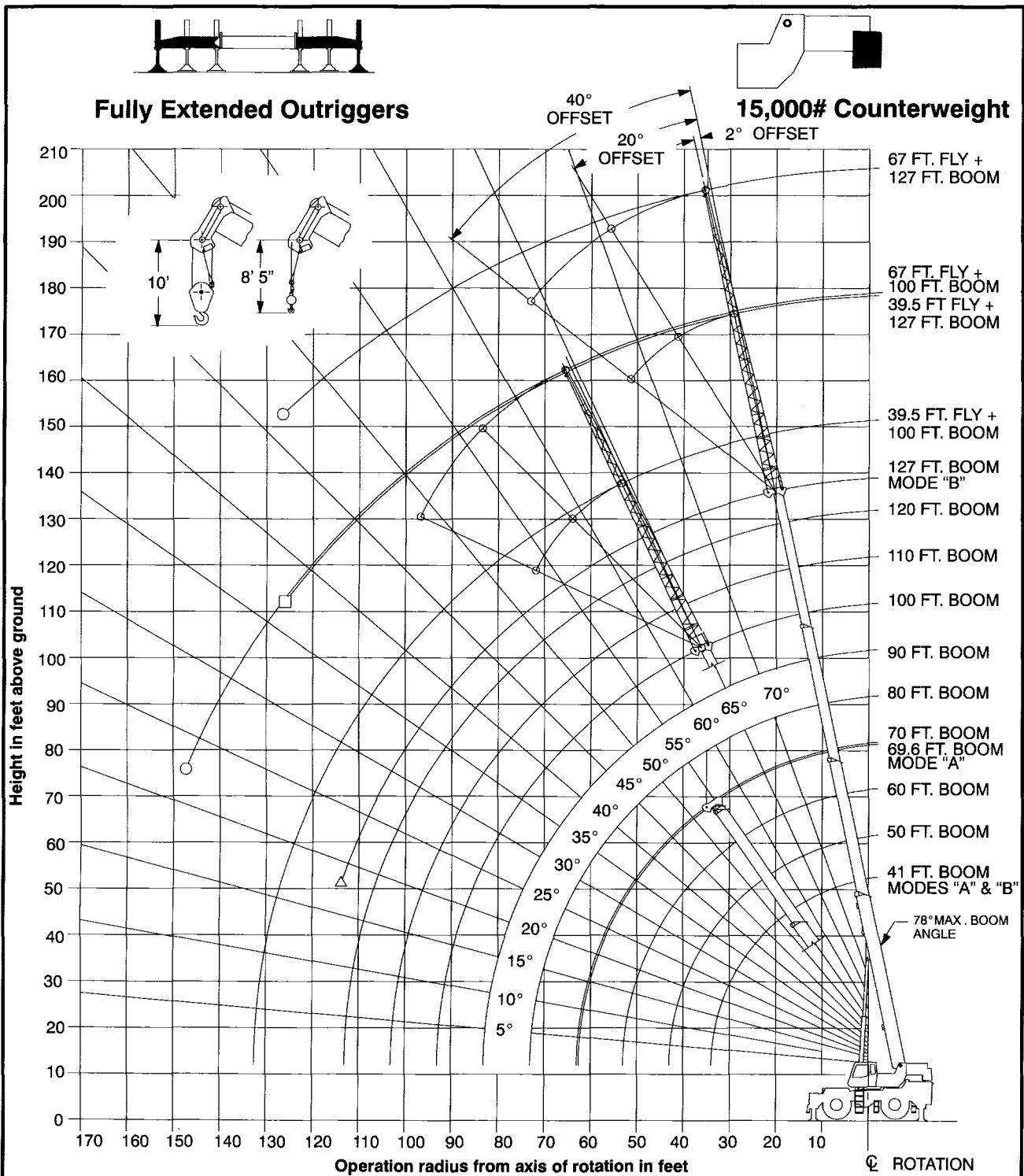

Note: Boom and fly geometry shown are for unloaded condition and crane standing level on firm supporting surface. Boom deflection, subsequent radius and boom angle change must be accounted for when applying load to hook.



WARNING

Do Not Lower The Boom Below The Minimum Boom Angle For No Load Stability As Shown In The Lift Charts For The Boom Lengths Given. Loss Of Stability Will Occur Causing A Tipping Condition.

Fully Extended Outriggers - Main Boom Capacities

Rated Lifting Capacities In Pounds Fully Extended Outriggers See Set Up Note 2.



Load Radius (Ft.)	FULL 15,000# MAIN BOOM "A"						Load Radius (Ft.)
	41 Ft.			50 Ft.			
	∠°	360°	Over Front	∠°	360°	Over Front	
9	70.5	140,000	140,000				9
10	69.0	128,600	128,600	73.0	75,100	75,100	10
12	66.0	116,500	118,900	70.5	75,100	75,100	12
15	61.0	100,100	101,800	67.0	75,100	75,100	15
20	52.5	74,700	74,700	60.5	74,100	74,100	20
25	42.5	57,600	57,600	53.5	57,000	57,000	25
30	29.0	45,900	45,900	45.5	45,500	45,500	30
35				36.0	35,200	37,200	35
40				23.0	27,200	29,300	40
Min. Boom Angle/Cap.	0 (34.0)	21,100	21,100	0 (43.0)	15,900	15,900	Min. Boom Angle/Cap.

Rated Lifting Capacities In Pounds Fully Extended Outriggers See Set Up Note 2.

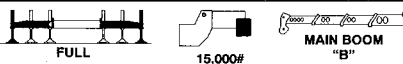

Load Radius (Ft.)	FULL 15,000# MAIN BOOM "B"						Load Radius (Ft.)
	41 Ft.			50 Ft.			
	∠°	360°	Over Front	∠°	360°	Over Front	
9	70.5	140,000	140,000				9
10	69.0	128,600	128,600	73.0	38,000	38,000	10
12	66.0	116,500	118,900	70.5	38,000	38,000	12
15	61.0	100,100	101,800	67.0	38,000	38,000	15
20	52.5	74,700	74,700	60.5	38,000	38,000	20
25	42.5	57,600	57,600	53.0	38,000	38,000	25
30	29.0	45,900	45,900	45.5	38,000	38,000	30
35				36.0	36,800	38,000	35
40				23.0	28,700	30,800	40
Min. Boom Angle/Cap.	0 (34.0)	21,100	21,100	0 (43.0)	14,900	14,900	Min. Boom Angle/Cap.

Load Radius (Ft.)	60 Ft.			69.6 Ft.			Load Radius (Ft.)
	∠°	360°	Over Front	∠°	360°	Over Front	
	10	76.5	74,000	74,000			
12	74.5	74,000	74,000	76.5	43,900	43,900	12
15	71.5	74,000	74,000	74.5	43,900	43,900	15
20	66.0	73,600	73,600	70.0	43,900	43,900	20
25	60.5	56,600	56,600	65.5	43,900	43,900	25
30	55.0	45,100	45,100	61.0	37,900	37,900	30
35	48.5	34,600	36,900	56.0	33,200	33,200	35
40	41.0	26,600	28,800	50.5	26,200	28,300	40
45	32.5	21,100	22,900	44.5	20,700	22,500	45
50	21.0	16,900	18,500	37.5	16,600	18,100	50
55				29.5	13,500	14,800	55
60				18.5	10,900	12,100	60
Min. Boom Angle/Cap.	0 (53.0)	10,800	10,800	0 (62.6)	7,300	7,300	Min. Boom Angle/Cap.

Load Radius (Ft.)	60 Ft.			70 Ft.			Load Radius (Ft.)
	∠°	360°	Over Front	∠°	360°	Over Front	
	10	76.0	38,000	38,000			
12	74.0	38,000	38,000	76.5	38,000	38,000	12
15	71.0	38,000	38,000	74.5	38,000	38,000	15
20	66.0	38,000	38,000	70.0	38,000	38,000	20
25	60.5	38,000	38,000	65.5	38,000	38,000	25
30	54.5	38,000	38,000	61.0	38,000	38,000	30
35	48.5	37,300	38,000	55.5	37,700	38,000	35
40	41.0	29,200	31,400	50.5	29,500	31,700	40
45	32.5	23,600	25,400	44.5	23,900	25,600	45
50	21.0	19,300	20,800	38.0	19,700	21,200	50
55				30.0	16,400	17,700	55
60				19.5	13,800	15,000	60
Min. Boom Angle/Cap.	0 (53.0)	10,500	10,500	0 (63.0)	7,600	7,600	Min. Boom Angle/Cap.

Note: Refer To Page 5 For "Capacity Deductions For Auxiliary Load Handling Equipment".

∠ Loaded Boom Angle In Degrees.

() Reference Radius For Minimum Boom Angle Capacities (Shown In Parenthesis) Are In Feet.

Note: Refer To Page 5 For "Capacity Deductions For Auxiliary Load Handling Equipment".

∠ Loaded Boom Angle In Degrees.

() Reference Radius For Minimum Boom Angle Capacities (Shown In Parenthesis) Are In Feet.

Rated Lifting Capacities In Pounds Fully Extended Outriggers See Set Up Note 2.

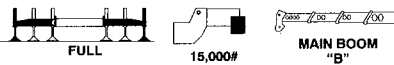

Load Radius (Ft.)	80 Ft.			90 Ft.			100 Ft.			Load Radius (Ft.)
	∠°	360°	Over Front	∠°	360°	Over Front	∠°	360°	Over Front	
	15	76.5	38,000	38,000						
20	73.0	38,000	38,000	75.0	38,000	38,000	77.0	37,400	37,400	20
25	69.5	38,000	38,000	72.0	38,000	38,000	74.0	32,700	32,700	25
30	65.5	38,000	38,000	68.5	37,900	37,900	71.0	29,000	29,000	30
35	61.0	37,900	38,000	65.0	33,900	33,900	68.0	26,000	26,000	35
40	56.5	29,700	31,900	61.5	29,900	30,500	65.0	23,400	23,400	40
45	52.0	24,100	25,800	57.5	24,300	26,000	61.5	21,200	21,200	45
50	47.0	19,900	21,400	53.5	20,000	21,600	58.0	19,300	19,300	50
55	41.5	16,600	18,000	49.0	16,800	18,100	54.5	16,900	17,700	55
60	35.5	14,000	15,200	44.5	14,200	15,400	50.5	14,300	15,500	60
65	28.0	12,000	13,000	39.5	12,100	13,100	46.5	12,300	13,200	65
70	18.0	10,200	11,200	33.5	10,400	11,400	42.5	10,500	11,500	70
75				26.5	8,900	9,800	37.5	9,000	9,900	75
80				17.0	7,600	8,400	32.0	7,800	8,600	80
85							25.5	6,700	7,400	85
90							16.5	5,700	6,400	90
Min. Boom Angle/Cap.	0 (73.0)	5,500	5,500	0 (83.0)	3,900	3,900	0 (93.0)	2,700	2,700	Min. Boom Angle/Cap.

Note: Refer To Page 5 For "Capacity Deductions For Auxiliary Load Handling Equipment".

∠ Loaded Boom Angle In Degrees.

() Reference Radius For Minimum Boom Angle Capacities (Shown In Parenthesis) Are In Feet.

Rated Lifting Capacities In Pounds Fully Extended Outriggers See Set Up Note 2.

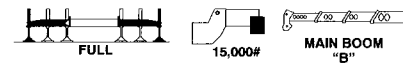

Load Radius (Ft.)	110 Ft.			120 Ft.			127 Ft.			Load Radius (Ft.)
	∠°	360°	Over Front	∠°	360°	Over Front	∠°	360°	Over Front	
	25	76.0	29,400	29,400	77.5	23,300	23,300	78.0*	19,600	
30	73.5	26,200	26,200	75.0	23,300	23,300	76.0	19,600	19,600	30
35	70.5	23,500	23,500	72.5	21,500	21,500	74.0	19,600	19,600	35
40	68.0	21,200	21,200	70.0	19,400	19,400	71.5	18,400	18,400	40
45	65.0	19,200	19,200	67.5	17,600	17,600	69.0	16,400	16,400	45
50	62.0	17,400	17,400	65.0	15,800	15,800	66.5	14,900	14,900	50
55	59.0	15,800	15,800	62.0	14,400	14,400	64.0	13,600	13,600	55
60	55.5	14,400	14,500	59.5	13,200	13,200	61.5	12,500	12,500	60
65	52.0	12,400	13,300	56.5	12,200	12,200	59.0	11,500	11,500	65
70	48.5	10,600	11,600	53.5	10,700	11,200	56.0	10,800	10,600	70
75	44.5	9,100	10,000	50.0	9,200	10,100	53.0	9,200	9,700	75
80	40.5	7,900	8,700	46.5	7,900	8,800	50.0	8,000	8,800	80
85	36.0	6,800	7,500	43.0	6,800	7,600	47.0	6,900	7,600	85
90	31.0	5,800	6,500	39.0	5,900	6,600	43.5	5,900	6,600	90
95	24.5	5,000	5,600	34.5	5,100	5,700	39.5	5,100	5,800	95
100	16.0	4,200	4,800	29.5	4,300	4,900	35.5	4,400	5,000	100
105				24.0	3,600	4,200	31.0	3,700	4,300	105
110				15.5	3,000	3,600	25.5	3,100	3,700	110
115							19.0	2,600	3,100	115
Min. Boom Angle/Cap.	0 (103.0)	1,700	1,700	0 (113.0)	900	900	18.0 (115.4)			Min. Boom Angle/Cap.

Note: Refer To Page 5 For "Capacity Deductions For Auxiliary Load Handling Equipment".

∠ Loaded Boom Angle In Degrees.

() Reference Radius For Minimum Boom Angle Capacities (Shown In Parenthesis) Are In Feet.

* This capacity based on maximum obtainable boom angle.

Fully Extended Outriggers - Fly Capacities - Boom Mode "B"

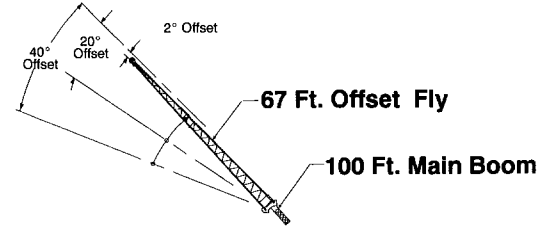
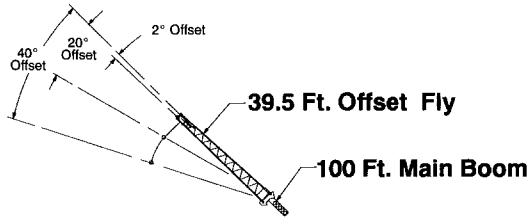

Rated Lifting Capacities In Pounds Fully Extended Outriggers See Set Up Note 2.

FULL 15,000#

Load Radius (Ft.)	2° Offset		20° Offset		40° Offset		Load Radius (Ft.)
	∠	360°	∠	360°	∠	360°	
30	77.0	13,900					30
35	75.0	13,400					35
40	73.0	12,800					40
45	71.0	12,200	76.0	9,400			45
50	69.0	11,700	74.0	8,900			50
55	67.0	11,100	71.5	8,500	76.0	6,600	55
60	64.5	10,600	69.5	8,100	73.5	6,400	60
65	62.5	10,100	67.0	7,800	71.0	6,300	65
70	60.0	9,700	64.5	7,400	68.5	6,100	70
75	57.5	9,200	62.0	7,200	66.0	6,000	75
80	55.0	8,700	59.5	6,900	63.5	5,800	80
85	52.5	8,300	57.0	6,600	60.5	5,700	85
90	49.5	7,900	54.0	6,400	57.5	5,600	90
95	46.5	6,500	51.5	6,200	54.5	5,500	95
100	43.0	5,700	48.0	6,000	51.5	5,500	100
105	39.5	5,000	45.0	5,500	47.5	5,400	105
110	36.0	4,400	41.0	4,800	43.5	5,100	110
115	32.0	3,900	36.5	4,200	38.5	4,400	115
120	27.5	3,400	32.0	3,700			120
125	22.0	2,900	26.0	3,100			125
130	14.0	2,500					130
Min. Boom Angle/Cap.	0	600	0	600	0	700	Min. Boom Angle/Cap.

Rated Lifting Capacities In Pounds Fully Extended Outriggers See Set Up Note 2.

FULL 15,000#

Load Radius (Ft.)	2° Offset		20° Offset		40° Offset		Load Radius (Ft.)
	∠	360°	∠	360°	∠	360°	
40	77.0	8,300					40
45	75.5	7,900					45
50	73.5	7,500					50
55	72.0	7,100					55
60	70.0	6,600	77.0	4,700			60
65	68.5	6,200	75.5	4,500			65
70	66.5	5,800	73.5	4,200			70
75	64.5	5,500	71.5	4,000			75
80	62.5	5,200	69.5	3,900	76.0	3,000	80
85	60.5	4,900	67.5	3,700	74.0	3,000	85
90	58.5	4,600	65.5	3,500	72.0	2,900	90
95	56.5	4,400	63.5	3,400	69.5	2,800	95
100	54.5	4,200	61.5	3,300	67.5	2,700	100
105	52.0	3,900	59.0	3,200	65.0	2,700	105
110	50.0	3,800	57.0	3,100	62.5	2,600	110
115	47.5	3,600	54.5	3,000	60.0	2,600	115
120	45.0	3,400	52.0	2,900	57.0	2,500	120
125	42.5	3,300	49.0	2,800	54.0	2,500	125
130	39.5	3,100	46.5	2,700	50.5	2,500	130
135	36.5	2,800	43.0	2,600	47.0	2,500	135
140	33.0	2,400	39.5	2,600	42.5	2,500	140
145	29.0	2,100	35.5	2,500			145
150	24.5	1,800	30.5	2,100			150
155			24.0	1,700			155
Min. Boom Angle/Cap.							Min. Boom Angle/Cap.

Note: Refer To Page 5 For "Capacity Deductions For Auxiliary Load Handling Equipment".

∠ Loaded Boom Angle In Degrees.

() Reference Radius For Minimum Boom Angle Capacities (Shown In Parenthesis) Are In Feet.

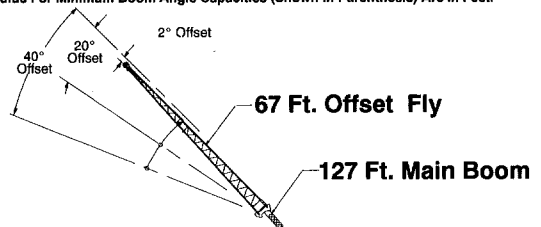
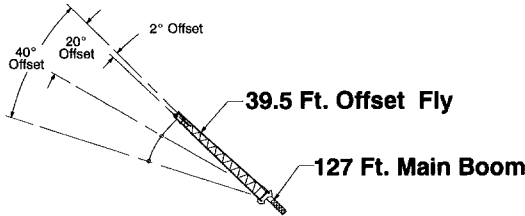

Rated Lifting Capacities In Pounds Fully Extended Outriggers See Set Up Note 2.

FULL 15,000#

Load Radius (Ft.)	2° Offset		20° Offset		40° Offset		Load Radius (Ft.)
	∠	360°	∠	360°	∠	360°	
35	78.0*	8,300					35
40	76.5	8,300					40
45	75.0	8,300					45
50	73.5	8,300	78.0*	8,200			50
55	71.5	8,300	76.0	8,000			55
60	70.0	8,300	74.5	7,800			60
65	68.5	8,300	72.5	7,600	76.0	6,200	65
70	67.0	8,300	71.0	7,400	74.5	6,100	70
75	65.0	7,800	69.0	7,200	72.5	6,000	75
80	63.0	7,100	67.0	7,000	70.5	5,800	80
85	60.5	6,600	65.5	6,800	68.5	5,700	85
90	58.5	6,000	63.0	6,300	66.5	5,700	90
95	56.5	5,600	61.0	5,800	64.0	5,600	95
100	54.5	5,100	58.5	5,300	62.0	5,500	100
105	52.0	4,700	56.5	4,900	59.5	5,100	105
110	49.5	4,100	54.0	4,500	57.0	4,700	110
115	47.0	3,500	51.0	4,000	54.0	4,300	115
120	44.0	3,000	48.5	3,500	51.0	3,800	120
125	41.5	2,600	45.5	3,000	48.0	3,200	125
130	38.5	2,100	42.5	2,500	44.5	2,700	130
135			39.0	2,100	40.5	2,200	135
Min. Boom Angle/Cap.							Min. Boom Angle/Cap.

Rated Lifting Capacities In Pounds Fully Extended Outriggers See Set Up Note 2.

FULL 15,000#

Load Radius (Ft.)	2° Offset		20° Offset		40° Offset		Load Radius (Ft.)
	∠	360°	∠	360°	∠	360°	
50	76.5	5,500					50
55	75.5	5,500					55
60	74.0	5,500					60
65	73.0	5,500					65
70	71.5	5,500	77.5	4,200			70
75	70.0	5,300	76.0	4,000			75
80	68.5	5,100	74.5	3,900			80
85	67.0	4,900	73.0	3,800			85
90	65.5	4,800	71.5	3,800	77.0	2,900	90
95	64.0	4,800	70.0	3,500	75.0	2,800	95
100	62.0	4,300	68.0	3,400	73.5	2,800	100
105	60.5	3,900	66.5	3,300	71.5	2,700	105
110	58.5	3,600	64.5	3,200	70.0	2,800	110
115	56.5	3,200	63.0	3,100	68.0	2,800	115
120	54.5	2,900	61.0	3,000	66.0	2,800	120
125	52.5	2,700	59.0	2,900	64.0	2,500	125
130	50.5	2,400	57.0	2,800	61.5	2,500	130
135	48.5	2,200	54.5	2,300	59.5	2,500	135
140			52.5	2,100	57.0	2,300	140
145			50.0	1,900	54.5	2,000	145
150			47.5	1,700	51.5	1,800	150
155					48.5	1,600	155
Min. Boom Angle/Cap.							Min. Boom Angle/Cap.

WARNING

Do Not Lower 67 Ft. Offset Fly In Working Position Below 22.5 Degrees Main Boom Angle Unless Main Boom Length Is 94 Ft. Or Less, Since Loss Of Stability Will Occur Causing A Tipping Condition.

Note: Refer To Page 5 For "Capacity Deductions For Auxiliary Load Handling Equipment".

∠ Loaded Boom Angle In Degrees.

() Reference Radius For Minimum Boom Angle Capacities (Shown In Parenthesis) Are In Feet.

WARNING

Do Not Lower 67 Ft. Offset Fly In Working Position Below 46.5 Degrees Main Boom Angle Unless Main Boom Length Is 94 Ft. Or Less, Since Loss Of Stability Will Occur Causing A Tipping Condition.

Note: Refer To Page 5 For "Capacity Deductions For Auxiliary Load Handling Equipment".

∠ Loaded Boom Angle In Degrees.

WORKING RANGE DIAGRAM

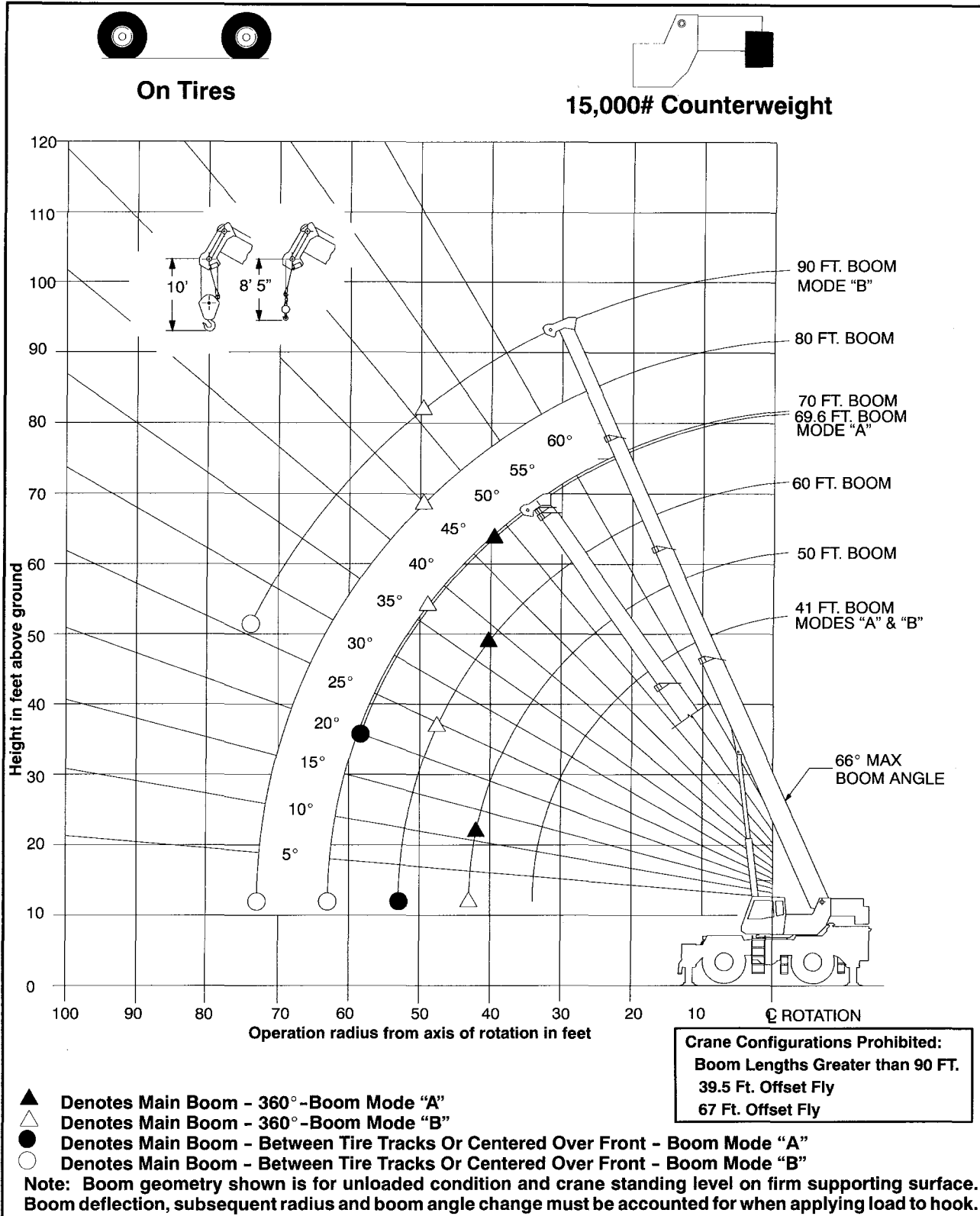

WARNING

Do Not Lower The Boom Below The Minimum Boom Angle For No Load Stability Or Raise Boom Above 66° As Shown In The Lift Chart For The Boom Lengths Given. Loss Of Stability Will Occur Causing A Tipping Condition.

On Tires (29.5 x 25 - 28 Ply) - Main Boom Capacities (15,000 lb. Counterweight)

On Tire Capacities In Pounds
Tire Pressure: See Page 5
Stationary Capacities
Over Front Between Tire Tracks
See Operation Note 20.

ON TIRES 15,000# MAIN BOOM "A"

Load Radius (Ft.)	41 Ft.		50 Ft.		Load Radius (Ft.)
	∠°	Load	∠°	Load	
15	61.0	54,900			15
20	52.5	42,500	60.5	42,000	20
25	42.0	29,200	53.0	28,600	25
30	29.0	20,800	45.0	20,500	30
35			36.0	15,100	35
40			23.0	11,400	40
Min. Boom Angle/Cap.	0 (34.0)	16,200	0 (43.0)	9,500	Min. Boom Angle/Cap.

Load Radius (Ft.)	60 Ft.		69.6 Ft.		Load Radius (Ft.)
	∠°	Load	∠°	Load	
25	60.5	28,000	65.0	27,600	25
30	54.5	20,000	60.5	19,600	30
35	48.0	14,800	55.5	14,500	35
40	41.0	11,100	50.0	10,900	40
45	32.5	8,400	44.0	8,200	45
50	21.0	6,200	37.5	6,100	50
55			29.5	4,400	55
Min. Boom Angle/Cap.	0 (53.0)	5,100	20.0 (59.2)		Min. Boom Angle/Cap.

Note: Refer To Page 5 For "Capacity Deductions For Auxiliary Load Handling Equipment".

∠ Loaded Boom Angle In Degrees.

() Reference Radius For Minimum Boom Angle Capacities (Shown In Parenthesis) Are In Feet.

On Tire Capacities In Pounds
Tire Pressure: See Page 5
Stationary Capacities
Over Front Between Tire Tracks
See Operation Note 20.

ON TIRES 15,000# MAIN BOOM "B"

Load Radius (Ft.)	41 Ft.		50 Ft.		60 Ft.		Load Radius (Ft.)
	∠°	Load	∠°	Load	∠°	Load	
15	61.0	54,900					15
20	52.5	42,500	60.0	38,000			20
25	42.0	29,200	53.0	29,900	60.5	30,300	25
30	29.0	20,800	45.0	21,700	54.5	22,100	30
35			36.0	16,300	48.0	16,800	35
40			23.0	12,500	41.0	13,000	40
45					32.5	10,200	45
50					20.5	8,100	50
Min. Boom Angle/Cap.	0 (34.0)	16,200	0 (43.0)	10,600	0 (53.0)	6,900	Min. Boom Angle/Cap.

Load Radius (Ft.)	70 Ft.		80 Ft.		90 Ft.		Load Radius (Ft.)
	∠°	Load	∠°	Load	∠°	Load	
25	65.0	30,600					25
30	60.5	22,400	64.5	22,600			30
35	55.5	17,100	60.5	17,300	64.5	17,400	35
40	50.0	13,400	56.0	13,500	60.5	13,600	40
45	44.5	10,600	51.5	10,900	57.0	11,000	45
50	37.5	8,400	46.5	8,700	53.0	8,900	50
55	30.0	6,700	41.5	7,000	48.5	7,200	55
60	19.0	5,300	35.0	5,600	44.0	5,800	60
65			28.0	4,400	39.0	4,600	65
70			18.0	3,400	33.0	3,600	70
Min. Boom Angle/Cap.	0 (63.0)	4,500	0 (73.0)	2,900	26.0 (75.3)		Min. Boom Angle/Cap.

Note: Refer To Page 5 For "Capacity Deductions For Auxiliary Load Handling Equipment".

∠ Loaded Boom Angle In Degrees.

() Reference Radius For Minimum Boom Angle Capacities (Shown In Parenthesis) Are In Feet.

On Tire Capacities In Pounds
Tire Pressure: See Page 5
Pick & Carry Capacities
(1mph) Boom Centered Over Front
See Operation Note 20.

ON TIRES 15,000# MAIN BOOM "A"

Load Radius (Ft.)	41 Ft.		50 Ft.		Load Radius (Ft.)
	∠°	Load	∠°	Load	
15	61.0	51,400			15
20	52.5	39,100	60.0	38,700	20
25	42.0	29,200	53.0	28,600	25
30	29.0	20,800	45.0	20,500	30
35			36.0	15,100	35
40			23.0	11,300	40
Min. Boom Angle/Cap.	0 (34.0)	16,200	0 (43.0)	9,500	Min. Boom Angle/Cap.

Load Radius (Ft.)	60 Ft.		69.6 Ft.		Load Radius (Ft.)
	∠°	Load	∠°	Load	
25	60.5	28,000	65.0	27,500	25
30	54.5	20,000	60.5	19,600	30
35	48.0	14,800	55.5	14,400	35
40	41.0	11,100	50.0	10,900	40
45	32.5	8,300	44.0	8,200	45
50	21.0	6,200	37.5	6,000	50
55			29.5	4,400	55
Min. Boom Angle/Cap.	0 (53.0)	5,100	20.0 (59.2)		Min. Boom Angle/Cap.

Note: Refer To Page 5 For "Capacity Deductions For Auxiliary Load Handling Equipment".

∠ Loaded Boom Angle In Degrees.

() Reference Radius For Minimum Boom Angle Capacities (Shown In Parenthesis) Are In Feet.

On Tire Capacities In Pounds
Tire Pressure: See Page 5
Pick & Carry Capacities
(1mph) Boom Centered Over Front
See Operation Note 20.

ON TIRES 15,000# MAIN BOOM "B"

Load Radius (Ft.)	41 Ft.		50 Ft.		60 Ft.		Load Radius (Ft.)
	∠°	Load	∠°	Load	∠°	Load	
15	61.0	51,400					15
20	52.5	39,100	60.0	38,000			20
25	42.0	29,200	53.0	29,900	60.5	30,300	25
30	29.0	20,800	45.0	21,700	54.5	22,100	30
35			36.0	16,300	48.0	16,800	35
40			23.0	12,500	41.0	13,000	40
45					32.5	10,200	45
50					20.5	8,100	50
Min. Boom Angle/Cap.	0 (34.0)	16,200	0 (43.0)	10,600	0 (53.0)	6,900	Min. Boom Angle/Cap.

Load Radius (Ft.)	70 Ft.		80 Ft.		90 Ft.		Load Radius (Ft.)
	∠°	Load	∠°	Load	∠°	Load	
25	65.0	30,600					25
30	60.5	22,400	64.5	22,600			30
35	55.5	17,100	60.5	17,300	64.5	17,400	35
40	50.0	13,400	56.0	13,500	60.5	13,600	40
45	44.5	10,600	51.5	10,900	57.0	11,000	45
50	37.5	8,400	46.5	8,700	53.0	8,900	50
55	30.0	6,700	41.5	7,000	48.5	7,200	55
60	19.0	5,300	35.0	5,600	44.0	5,800	60
65			28.0	4,400	39.0	4,600	65
70			18.0	3,400	33.0	3,600	70
Min. Boom Angle/Cap.	0 (63.0)	4,500	0 (73.0)	2,900	26.0 (75.3)		Min. Boom Angle/Cap.

Note: Refer To Page 5 For "Capacity Deductions For Auxiliary Load Handling Equipment".

∠ Loaded Boom Angle In Degrees.

() Reference Radius For Minimum Boom Angle Capacities (Shown In Parenthesis) Are In Feet.

On Tires (29.5 x 25 - 28 Ply) - Main Boom Capacities (15,000 lb. Counterweight)

On Tire Capacities In Pounds Tire Pressure: See Page 5 Stationary Capacities-360 Degrees See Operation Note 20.					
360° ON TIRES 15,000# MAIN BOOM "A"					
Load Radius (Ft.)	41 Ft.		50 Ft.		Load Radius (Ft.)
	∠°	Load	∠°	Load	
15	61.0	33,500			15
20	52.5	20,500	60.0	20,000	20
25	42.0	13,500	53.0	13,100	25
30	29.0	9,100	45.0	8,800	30
35			35.5	5,800	35
40			23.0	3,700	40
Min. Boom Angle/Cap.	0 (34.0)	6,500	11.5 (42.5)		Min. Boom Angle/Cap.

WARNING
Do Not Raise The Boom Above 66 Degrees. Loss Of Backward Stability Will Occur Causing A Tipping Condition.

Load Radius (Ft.)	60 Ft.		69.6 Ft.		Load Radius (Ft.)
	∠°	Load	∠°	Load	
25	60.0	12,800	65.0	12,500	25
30	54.5	8,500	60.0	8,300	30
35	48.0	5,600	55.0	5,400	35
40	41.0	3,500	49.5	3,300	40
Min. Boom Angle/Cap.	38.0 (41.7)		48.0 (41.3)		Min. Boom Angle/Cap.

WARNING
Do Not Raise The Boom Above 66 Degrees. Loss Of Backward Stability Will Occur Causing A Tipping Condition.

Note: Refer To Page 5 For "Capacity Deductions For Auxiliary Load Handling Equipment".

∠° Loaded Boom Angle In Degrees.

() Reference Radius For Minimum Boom Angle Capacities (Shown In Parenthesis) Are In Feet.

On Tire Capacities In Pounds Tire Pressure: See Page 5 Stationary Capacities-360 Degrees See Operation Note 20.							
360° ON TIRES 15,000# MAIN BOOM "B"							
Load Radius (Ft.)	41 Ft.		50 Ft.		60 Ft.		Load Radius (Ft.)
	∠°	Load	∠°	Load	∠°	Load	
15	61.0	33,500	66.5	34,100			15
20	52.5	20,500	60.0	21,300			20
25	42.0	13,500	53.0	14,200	60.0	14,700	25
30	29.0	9,100	45.0	9,900	54.5	10,400	30
35			35.5	6,900	48.0	7,400	35
40			23.0	4,700	41.0	5,200	40
45					32.5	3,600	45
50							50
Min. Boom Angle/Cap.	0 (34.0)	6,500	0 (43.0)	3,600	24.5 (48.6)		Min. Boom Angle/Cap.

WARNING
Do Not Raise The Boom Above 66 Degrees. Loss Of Backward Stability Will Occur Causing A Tipping Condition.

Load Radius (Ft.)	70 Ft.		80 Ft.		90 Ft.		Load Radius (Ft.)
	∠°	Load	∠°	Load	∠°	Load	
25	65.0	15,000					25
30	60.0	10,800	64.5	10,900			30
35	55.5	7,800	60.5	8,000	64.0	8,100	35
40	50.0	5,600	56.0	5,800	60.5	6,000	40
45	44.0	3,900	51.5	4,200	56.5	4,300	45
50			46.5	2,900	52.5	3,000	50
Min. Boom Angle/Cap.	37.0 (50.3)		45.0 (51.3)		51.0 (52.1)		Min. Boom Angle/Cap.

WARNING
Do Not Raise The Boom Above 66 Degrees. Loss Of Backward Stability Will Occur Causing A Tipping Condition.

Note: Refer To Page 5 For "Capacity Deductions For Auxiliary Load Handling Equipment".

∠° Loaded Boom Angle In Degrees.

() Reference Radius For Minimum Boom Angle Capacities (Shown In Parenthesis) Are In Feet.

Specifications

Telescopic Boom Rough Terrain Crane

RTC-8070 70-ton (63.50 metric tons)

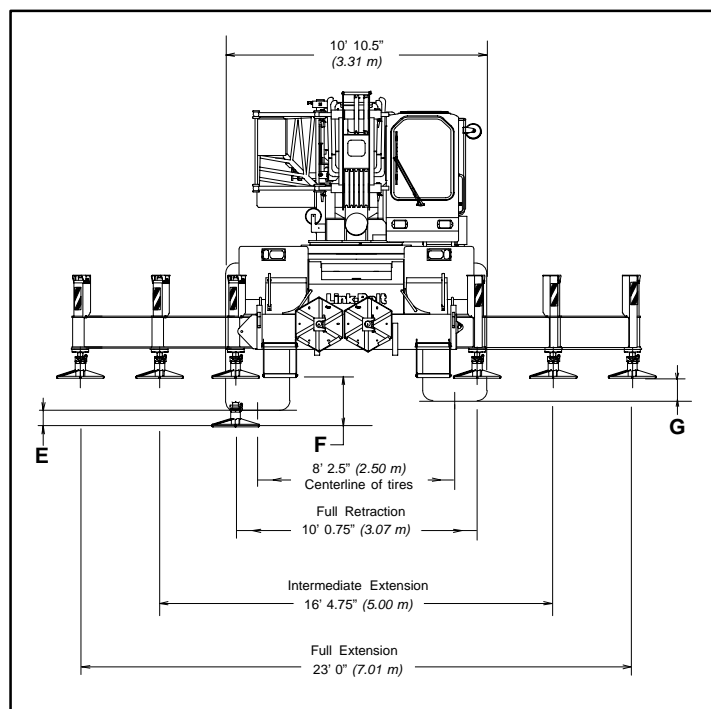
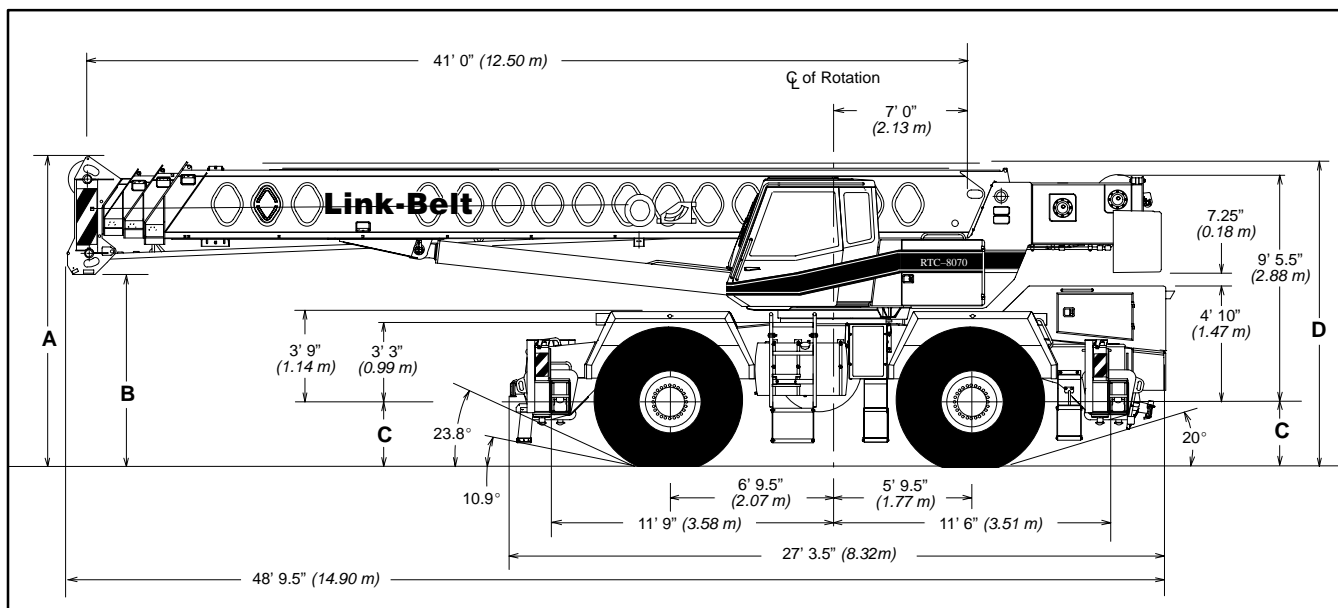

General Dimensions		feet	meters
Tailswing of Counterweight		13' 9.25"	4.20
Turning radius (4-wheel steer centerline of tires)		23' 10"	7.26
Turning radius (2-wheel steer centerline of tires)		46' 10"	14.28
Turning radius (4-wheel steer outside front carrier corner)		27' 5"	8.36
Turning radius (2-wheel steer outside front carrier corner)		49' 10"	15.19
Dimension	Tire Size		
	29.5 x 25	29.5 R 25	
A	12' 10.75" (3.93 m)	12' 11.75" (3.97 m)	
B	7' 11.5" (2.42 m)	8' 0.5" (2.44 m)	
C	2' 8" (0.81 m)	2' 9" (0.84 m)	
D	12' 5" (3.78 m)	12' 6" (3.81 m)	
E	8.25" (0.21 m)	7" (0.18 m)	
F	25.25" (0.64 m)	25.25" (0.64 m)	
G	11.25" (0.29 m)	12.25" (0.31 m)	

Upper Structure

■ Boom

Patented Design

- Boom side plates have diamond shaped impressions for superior strength to weight ratio and 100,000 psi (689.5 mPa) steel angle chords for lateral stiffness.
- Boom telescope sections are supported by top, bottom, and adjustable side wear shoes to prevent metal to metal contact.

Standard Boom

- 41' – 127' (12.50 – 38.71 m) four-section full power boom.
- Basic mode (or mode "B") is the full power, synchronized mode of telescoping all sections proportionally to 127' (38.71 m).
- The exclusive **A-max** mode (or mode "A") extends only the inner mid-section to 69.5' (21.18 m) offering increased capacities for in-close, maximum capacity picks.
- Mechanical Boom Angle Indicator

Boom Head

- Five 16.5" (0.42 m) root diameter steel nylon sheaves handle up to ten parts of wire rope.
- Quick reeve design
- Boom head designed for quick reeve of hook block
- Rope dead end lugs provided on each side of boom head
- Easily removable wire rope guards
- Fly pinning alignment tool

Boom Elevation

- Hydraulic cylinder with holding valves and bushing in each end
- Hand control for controlling boom elevation from -3 to +78°

Optional Auxiliary Lifting Sheave

- Single 16.5" (0.42 m) root diameter steel sheave with removable wire rope guard mounted on boom.
- Use with one or two parts of line.
- Does not affect erection of fly or use of main head sheaves for multiple reeving.

Optional

- 70-ton (63.5 mt) 5-sheave, quick reeve hook block
- 60-ton (54.43 mt) 4-sheave, quick reeve hook block
- 40-ton (36.28 mt) 4-sheave, quick reeve hook block
- 8.5-ton (7.7 mt) hook ball
- Boom floodlight

■ Fly

Optional

- 39.5' (12.04 m) offsettable, stowable one-piece lattice type with lugs to allow for second section. Can be offset 2°, 20°, or 40°.
- 39.5' – 67' (12.04 – 20.42 m) offsettable, stowable two-piece lattice type. Can be offset 2°, 20°, or 40°.

■ Cab and Controls

Environmental Cab

- LFC-2000 construction process featuring laminated fibrous composite material.
- Isolated from sound and vibration by a neoprene seal
- Six-way adjustable operator's seat with retractable seat belt
- Four-way adjustable tilting and locking steering wheel.
- All windows are tinted and tempered safety glass.
- Slide by door opens to 3' (0.91 m) width.
- Sliding rear and right side windows and swing up roof windows for maximum visibility and ventilation.
- Engine dependent warm-water heater with defroster.
- Outrigger controls and sight level bubble also provided in upper cab.
- Audible swing alarm.
- Backup alarm
- Cab mounted work lights
- Electric windshield wiper
- Top hatch window wiper
- Fire extinguisher
- Dome light
- Hand throttle
- Travel lights
- Sun visor
- Mirrors
- Cup holder
- Circulating fan
- Warning horn

Optional

- Amber strobe light and rotating beacon.
- Emergency steering system
- Air conditioning

Controls

Hydraulic controls (joystick type) for:

- Main winch
- Drum rotation indicators
- Optional auxiliary winch.
- Optional single-axis controls.
- Boom hoist
- Swing

Foot controls for:

- Boom telescope
- Swing brake
- Engine throttle with throttle lock

Cab Instrumentation

Corner post mounted gauges for:

- Hydraulic oil temperature
- Converter temperature
- Audio/Visual warning system
- Water temperature
- Tachometer
- Oil pressure
- Fuel
- Voltmeter

■ Rated Capacity Limiter

- **Microguard 434** Graphic audio-visual warning system built into dash with anti-two block and function limiters.

Operating data available includes:

- Crane configuration
- Boom length
- Head height
- Allowed load
- % of allowed load
- Boom angle
- Radius of load
- Actual load

Presetable alarms include:

- Maximum and minimum boom angles.
- Maximum tip height.
- Maximum boom length.
- Swing left/right positions.
- Operator defined area alarm is standard.
- Anti-two block weight designed for quick reeve of hookblock.

Optional

- **Internal RCL light bar:** Visually informs operator when crane is approaching maximum load capacity with a series of lights; green, yellow, and red.
- **External RCL light bar:** Visually informs ground crew when crane is approaching maximum load capacity kickouts and pre-settable alarms with a series of lights; green, yellow, and red.

■ Swing

- Bi-directional hydraulic swing motor mounted to a planetary reducer for 360° continuous smooth swing at 2 r.p.m.
- **Swing park brake** – 360° electric over hydraulic (spring applied, hydraulic released) multi-disc brake mounted on the speed reducer. Operated by toggle switch in overhead control console.
- **Swing brake** – 360°, foot operated, hydraulic applied disc brake mounted on the speed reducer.
- **Travel swing lock** – Standard; two position travel lock (pin device) operated from the operator's cab.
- **Counterweight** – Pinned to upper structure frame. 15,000 lb (6 804 kg). Optional hydraulically controlled counterweight removal.

Optional

- 360° (pawl-in-gear) swing lock (meets New York City requirements).

■ Hydraulic System

Main Pump

- Four-section gear-type pump.
- Combined pump capacity 132 gpm (500 Lpm).
- Mounted on torque converter, powered by engine through a pump disconnect.
- Pump disconnect is a spline type clutch engaged/disengaged from carrier.
- Pump operates at 3,500 psi (24.1 mPa) maximum system pressure.
- O-Ring Face Seal (ORFS) technology throughout with hydraulic oil cooler.

Pilot Pressure / Brake / Counterweight Removal

- Pressure compensated piston pump powered by carrier engine. Operates at 2,650 psi (18.3 mPa) maximum.

Telescope/Outrigger/Steering Pump

- Single gear-type pump, 24 gpm (91 Lpm) maximum. Mounted on torque converter, powered by engine through a direct mechanical drive.
- Pump operates at 3,000 psi (20.7 mPa) maximum system pressure.

Reservoir

- 170 gal (643.5 L) capacity. Diffuser for deaeration.

Filtration

- One, 10-micron filter located inside hydraulic reservoir. Accessible for easy replacement.

Control Valves:

- Six separate pilot operated control valves allow simultaneous operation of all crane functions.

Load Hoist System

Standard

- 2M rear winch with grooved lagging
- Two-speed motor and automatic brake
- Power up/down mode of operation.
- Controls for future addition of auxiliary winch.

- Bi-directional piston-type hydraulic motor, driven through a planetary reduction unit for positive operator control under all load conditions.
- Asynchronous parallel double crossover grooved drums minimize rope harmonic motion.
- Winch circuit control provides balanced oil flow to both winches for smooth, simultaneous operation.

Line Pulls and Speeds

- Maximum line pull 16,506 lb (7 487 kg) and maximum line speed of 454 f.p.m. (138.4 m/min) on standard 16" (0.41 m) root diameter grooved drum
- Rotation resistant rope

Optional

- 2M front winch with two-speed motor and automatic brake, power up/down mode of operation.
- Hoist drum cable followers
- Third wrap indicators

Carrier

Type

- 10' 10.5" (3.31 m) wide, 151" (3.84 m) wheelbase.
- 4 x 4 x 4 – (4-wheel steer, 4-wheel drive) For rough terrain with limited turning area.

Frame

- 100,000 psi (689.5 mPa) steel, double walled construction.
- Integral 100,000 psi (689.5 mPa) steel outrigger boxes.

Standard Carrier Equipment

- Two front, rear, and mid-point carrier steps
- Non-slip safety strips on carrier deck
- Deep front storage
- Fenders
- Pontoon storage
- Full lighting package
- Front towing shackles

Optional

- Front and rear mounted pintle hook
- Front tow winch

Engine

Engine	Caterpillar 3126B 7.2L
Cylinders – cycle	6 – 4
Bore	4.33 in. (110 mm)
Stroke	5.00 in. (127 mm)
Displacement	442 cu. in. (72 L)
Maximum brake hp	225 @ 2,200 rpm
Peak torque (ft. lb.)	646 @ 1,500 rpm
Electric system	12 volt
Starting system	12 volt
Fuel capacity	95 gal (359.61L)
Alternator	130 amps
Crankcase capacity (total system)	30 qt (28.4 L)
<ul style="list-style-type: none"> • Water/fuel separator on engine • Optional ether injection package 	

Transmission

- Spicer off-highway three-speed, two-range power shift transmission.
- Six speeds forward and reverse
- Front axle disconnect for two or four-wheel drive.

Axles

- Front and Rear – Heavy duty planetary drive/steer type
- Front axle disconnect

Suspension

Front Axle

- Rigid mounted to frame

Rear Axle

- Pin mounted on bronze bushings. Automatic hydraulic rear axle oscillation lock-out cylinders engage when upper structure rotates 2.5° past centerline.

Steering

- Hydraulic two-wheel, four-wheel, and "crab" steering.
- Modes selected by toggle switch on dash.
- All modes fully controlled by steering wheel.

Optional

- Rear steer indicator

Tires

Front and Rear

- Standard 29.5 x 25 (28-PR) Earthmover type

Optional

- 29.5R25 XHA 1 star radials
- Spare tires and rims.

Brakes

Service

- Hydraulic disc-type brakes at each wheel end.

Parking/Emergency

- Disc-type, spring applied, hydraulic released, fade resistant, operated from cab, mounted on front axles.

Outriggers

- Three position operation capability.
- Four hydraulic, telescoping beam and jack outriggers.
- Vertical jack cylinders equipped with integral holding valve.
- Beams extend to 23' 0" (7.01 m) centerline-to-centerline and retract to within 10' 10.5" (3.31 m) overall width.
- Equipped with stowable, lightweight 23.5" x 27.25" (59.7 x 69.2 cm) hexagonal steel pontoons.
- Controls and sight level bubble located in cab.

Confined Area Lifting Capacities (CALC™) System

- The crane is operational in one of the three outriggers positions and operational in confined areas in two positions (intermediate and full retraction). The three outrigger positions are:
 - Full extension – 23' 0" (7.01 m)
 - Intermediate position – 16' 4.75" (5.00 m)
 - Full retraction – 10' 0.75" (3.07 m)
- Capacities are provided with the outrigger beams in the intermediate and full retraction positions.
- When the outrigger position levers (located on the outrigger beams) are engaged, the operator can set the crane in the intermediate or full retraction outrigger position without having to leave the cab.

Optional

- Outrigger cover package

Travel Speeds and Gradeability

Tires	29.5 x 25
Maximum Speed	19.5 mph (31.4 km/h)
Gradeability at 70% converter efficiency	107.3%
Maximum Tractive Effort at 70% converter efficiency	76,715 lb (34 797 kg)
Gradeability at 1.0 mph (1.6 km/hr)	54%
Maximum Tractive Effort at 1.0 mph (1.6 km/hr)	50,516 lb (22 914 kg)
Crane operating angle must not exceed 35° (77% grade). Numbers reflect main hydraulic pump engaged.	

■ Axle Loads

Base crane with standard 41' to 127' (12.50 – 38.71 m) four-section boom, 2M main winch with 2-speed hoisting and power up/down, 670' (204 m) 3/4" (19 mm) wire rope. 4x4x4 carrier with Caterpillar 3126B 7.2L engine, 29.5 x 25 tires, counterweight, and no fuel.	G.V.W. ¹		Upper facing front				Upper facing rear			
			Front axle		Rear axle		Front axle		Rear axle	
	lb	kg	lb	kg	lb	kg	lb	kg	lb	kg
	93,514	42 417	43,540	19 749	49,974	22 668	42,540	19 296	50,974	23 121
Remove 29.5 x 25 tires and wheels	-6,732	-3 054	-3,366	-1 527	-3,366	-1 527	-3,366	-1 527	-3,366	-1 527
29.5R25 XHA Tires	964	438	482	219	482	219	482	219	482	219
Remove outrigger beams	-5,235	-2 374	-2,461	-1 116	-2,774	-1 258	-2,461	-1 116	-2,774	-1 258
Jack cylinder beams	154	70	72	33	82	27	72	33	82	37
Tow winch	686	311	1,002	454	-316	-143	1,002	454	-316	-143
100 gal (378.5 L) fuel	685	310	364	165	321	145	364	165	321	145
2M auxiliary winch with 670' (204 m) of 3/4" (19 mm) rope	823	373	-219	-99	1,043	473	977	443	-154	-70
Remove front carrier counterweights	-1,000	-454	-1,306	-592	306	139	-1,306	-592	306	139
Hydraulic counterweight removal	353	160	163	74	190	86	518	235	-165	-75
Remove counterweight	-15,000	-6 804	8,223	3 734	-23,233	-10 538	-22,041	-9 998	7,041	3 194
Air conditioning	287	130	55	25	232	105	209	95	78	35
39.5' (12.04 m) offsettable lattice fly stowed	1,602	727	2,780	1 261	-1,178	-534	-1,305	-592	2,907	1 319
39.5' – 67' (12.04 – 20.42 m) offsettable lattice fly stowed	2,380	1 080	3,649	1 655	-1,269	-576	-1,458	-661	3,838	1 741
Fly storage brackets with all fly options	160	73	268	122	-108	-49	-120	-54	280	127
Auxiliary lifting sheave assembly	110	50	361	164	-251	-114	-260	-118	370	168
8.5-ton (7.71 mt) hook ball @ front bumper	360	163	566	256	-206	-93	n/a	n/a	n/a	n/a
70-ton (63.50 mt) 5-sheave hook block @ front bumper	1,390	631	2,186	992	-796	-361	n/a	n/a	n/a	n/a
60-ton (54.43 mt) 4-sheave hook block @ front bumper	1,150	522	1,809	821	-659	-299	n/a	n/a	n/a	n/a

¹ – Adjust gross weight and axle loading according to component weight. Note: All weights are ± 3%.

Tire	Max. Axle Load @ 20 mph (32.2 km/hr)
29.5 x 25 (28-PR)	53,000 (24 041 kg)
29.5R25 XHA 1 Star	53,000 (24 041 kg)